



SHT Scissor Lifting Tables

Scissor lifting tables with electrohydraulic drives can carry up to 6,000 kg and provide ergonomic loading and unloading

- ▶ Suitable for heavy loads up to 6,000 kg.
- ▶ Electrohydraulic drive -- can also be provided with a hydropneumatic drive.
- ▶ Low-maintenance and trouble-free operation thanks to high quality, robust components.
- ▶ The tables adhere to the latest accident prevention regulations as well as applicable EN standards (DIN EN 1570) and the current EU machine directives.
- ▶ Optional accessories, such as removable guardrails, rollover valves, bellows, roller track attachments, special, turning and tipping platforms.
- ▶ Special designs available.



SHT

i AREAS OF APPLICATION

- Installation workplaces
- Shipping and goods receiving
- Compensation for height differences

TECHNICAL DATA

Equipment type	Load capacity (in kg)	Platform (in mm)		Design height (in mm)	Useful lift (in mm)	Lifting time (in seconds)	Mobile possible
		BL	LL				
SHT 0,5/70/90	500	700	900	160	600	12	✓
SHT 1/70/130	1.000	700	1.300	180	820	15	✓
SHT 1/70/170	1.000	700	1.700	180	1.100	27	✓
SHT 1/80/130	1.000	800	1.300	180	820	15	✓
SHT 1/80/200	1.000	800	2.000	200	1.300	16	✓
SHT 1/100/130	1.000	1.000	1.300	180	820	15	✓
SHT 1,5/100/170	1.500	1.000	1.700	230	1.100	17	✓
SHT 1,5/120/170	1.500	1.200	1.700	230	1.100	17	✓
SHT 2/80/130	2.000	800	1.300	200	820	17	✓
SHT 2/100/130	2.000	1.000	1.300	200	820	17	✓



Contact and advice:

+49 7161 98442-0
verkauf@ventzki.de

Or use our questionnaire at

www.ventzki.de/anfrage

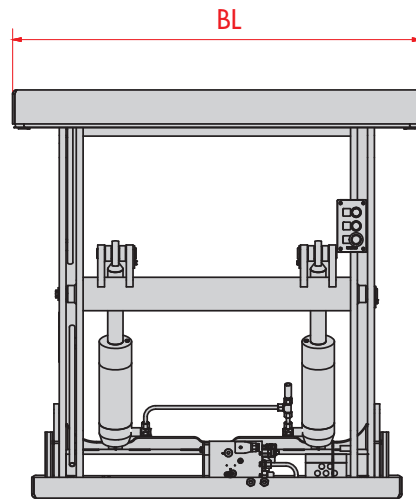
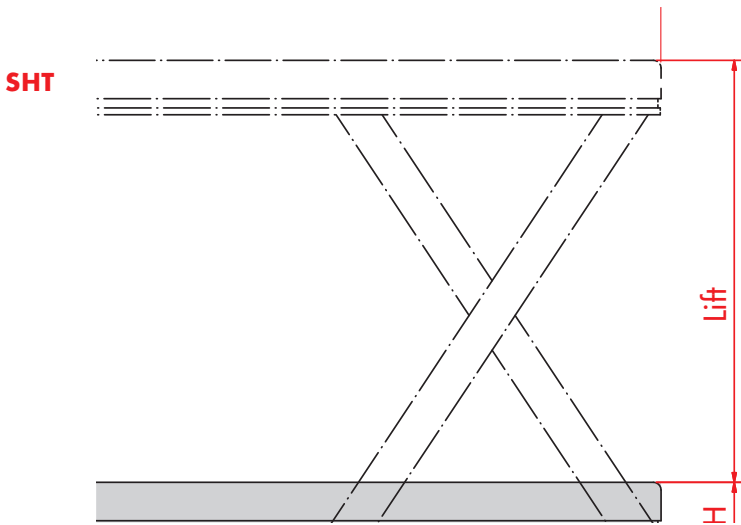

PRODUCT HIGHLIGHTS

- Surrounding safety contact strip
- Tube break valve in the cylinder
- Maintenance supports
- Load-independent power regulating valve

PRODUCT FILM

SHT at www.ventzki.de/produktfilme

Equipment type	Load capacity (in kg)	Platform (in mm)		Design height (in mm)	Useful lift (in mm)	Lifting time (in seconds)	Mobile possible
		BL	LL				
SHT 2/100/150	2.000	1.000	1.500	220	1.000	26	✓
SHT 2/120/150	2.000	1.200	1.500	220	1.000	26	✓
SHT 2/120/220	2.000	1.200	2.200	250	1.500	27	✓
SHT 2/150/220	2.000	1.500	2.200	250	1.500	27	✓
SHT 3/80/130	3.000	800	1.300	250	820	26	✓
SHT 3/90/170	3.000	900	1.700	250	1.100	27	✓
SHT 3/130/250	3.000	1.300	2.500	300	1.700	27	✓
SHT 3/150/300	3.000	1.500	3.000	400	2.000	38	✓

Larger load capacities and dimensions available on request. Power ratings: 400 V/50 Hz, 16 A, 5-pole. Paint: RAL 7035