

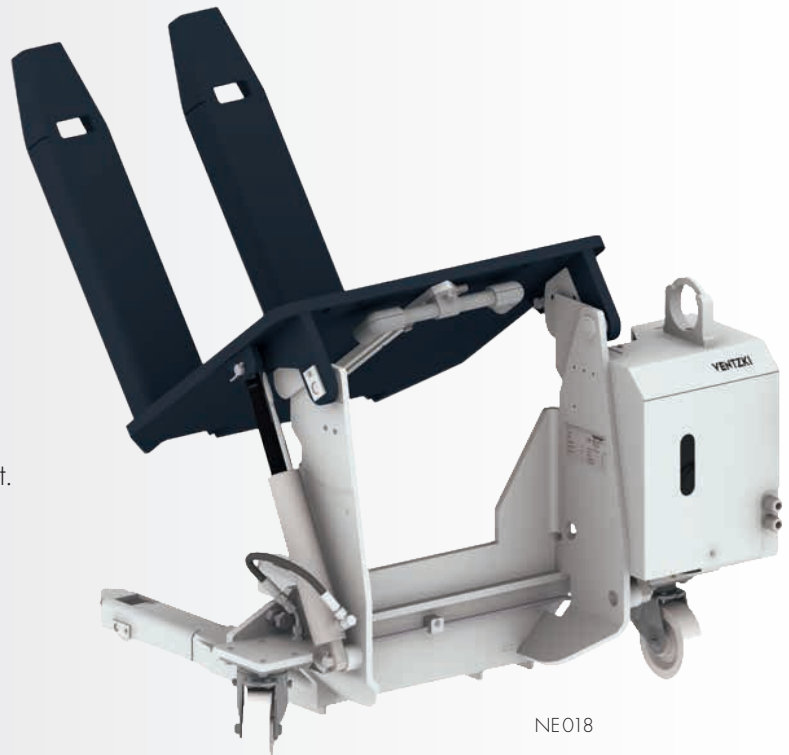

# NE 018/019

Mobile tipping equipment with electrohydraulic drive for flexible use with containers of all types up to 1,500 kg

- ▶ Electrohydraulic drive.
- ▶ Stepless setting of the tip angle.
- ▶ Ergonomic design using state of the art elements.
- ▶ Low-maintenance and trouble-free operation due to high-quality, robust components.
- ▶ Mobile use in different areas.
- ▶ Steering rollers with brake and casters.
- ▶ Hydropneumatic design adapted to customer's needs.
- ▶ Shifting bracket provided as standard equipment.



NE018

## **i** AREAS OF APPLICATION

- Foundries
- Manual industrial workplaces
- Metalworking

## TECHNICAL DATA

Equipment type	Load capacity (in kg)	Load handling (in mm)		Overlay (ZB in mm)	Loading height (in mm)	Tip	Mobile possible
		BL	LL				
<b>NE 018</b>	1.000	540	805	2 x 160 Zinken	90	90°	✓
<b>NE 019</b>	1.500	540	805	2 x 160 Zinken	90	90°	✓

Power: 400 V/50 Hz, 16 A, 5-pole. Paint: RAL 7035/7016



Contact and advice:

**+49 7161 98442-0**  
**verkauf@ventzki.de**

Or use our questionnaire at

**www.ventzki.de/anfrage**

## NE018

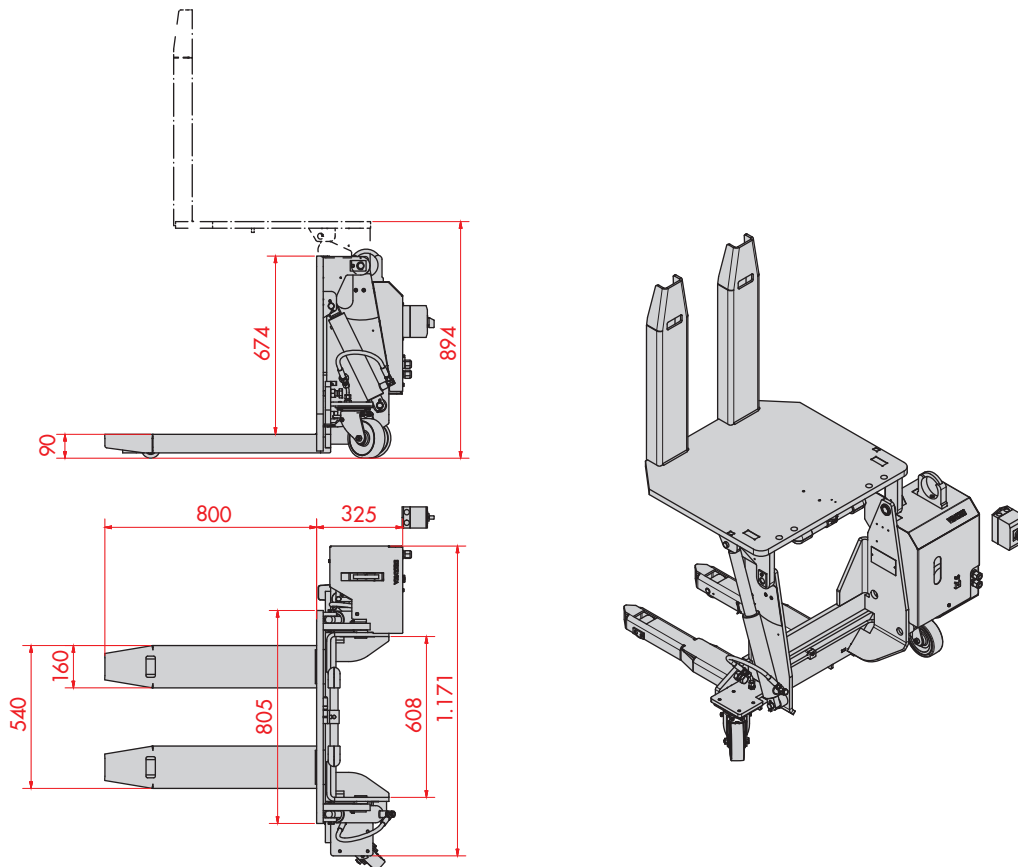

### ★ PRODUCT HIGHLIGHTS

- Mobile with steering rollers with and casters
- Stepless setting of the tip angle
- Compact design