



HP 200/250

Lifting equipment with pneumatic drive for stepless, adjustable ergonomic working heights for containers weighing up to 250 kg

- ▶ Suitable to carry small containers, carts, floor rollers and grating baskets.
- ▶ Load capacity, depending on model, from 200 to 250 kg.
- ▶ Sidewalls (in the HP 200).
- ▶ Pneumatic drive in accordance with the latest safety requirements.
- ▶ Safety valve equipment prevents the carrier dropping if there is a break in the line.
- ▶ Stepless adjustment to the desired ergonomic working height.
- ▶ Stationary equipment with side loading available.
- ▶ Low-maintenance and trouble-free operation thanks to high quality, robust components.

i AREAS OF APPLICATION

- Automobile and automobile supplier industries
- Positioning KLT's over floor rollers at the workplace



HP 200

TECHNICAL DATA

Equipment type	Load capacity (in kg)	Load handling (in mm)		Overlay (ZB in mm)	Loading director	Loading height (in mm)	Useful lift (in mm)	Mobile possible
		BL	LL					
HP 200	200	445	600	200	from the front	120	600	✓
HP 200	200	445	600	200	from the front	120	800	✓
HP 200 R/L	200	445	600	200	Side-loading (R/L)	120	600	✗
HP 200 R/L	200	445	600	200	Side-loading (R/L)	120	800	✗
HP 250	250	620	450	270	from the front	120	800	✓
HP 250 R/L	250	620	450	270	Side-loading (R/L)	120	800	✗

Connection: Compressed air 6 bar, Paint: RAL 7035/7016



Contact and advice:

+49 7161 98442-0
verkauf@ventzki.de

Or use our questionnaire at

www.ventzki.de/anfrage

HP 200 (stationary)

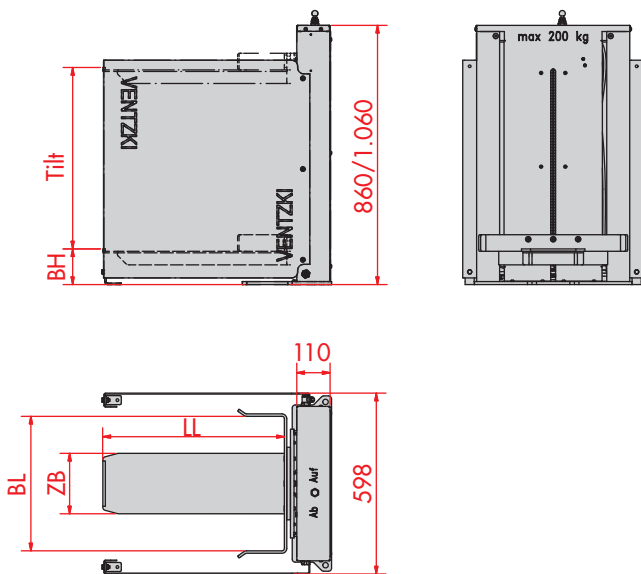

HP 250 (partially mobile)

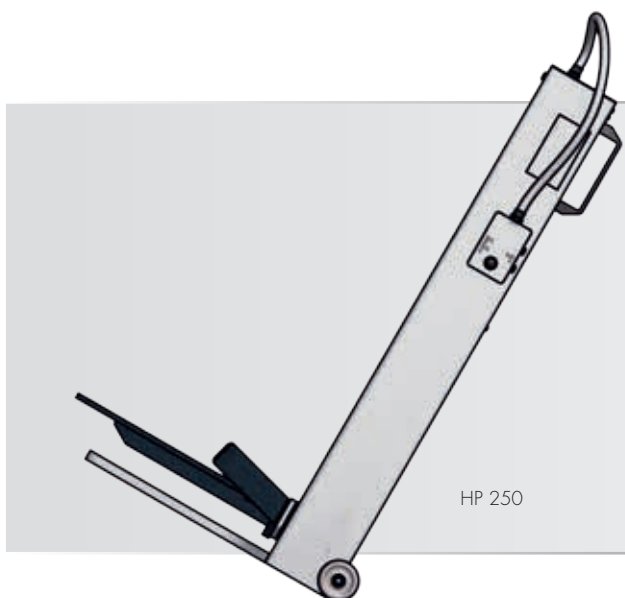
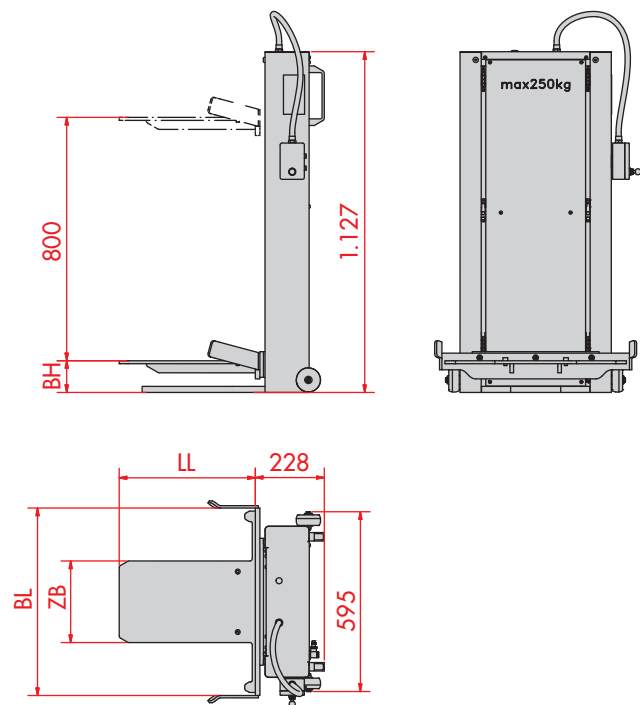

HP 250

PRODUCT HIGHLIGHTS

- low design depth and height of the lifting column, thus easier working with the containers

PRODUCT FILM

HP 200 and HP 250 at www.ventzki.de/produktfilm